

# 48" X 96" LEACHING GALLERIE

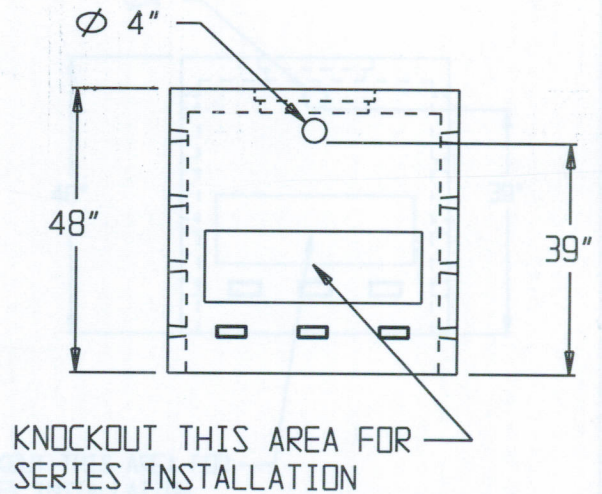

## SPECIFICATIONS:

- \* Concrete Minimum Compressive Strength-4,000 P.S.I at 28 days.
- \* Steel Reinforcement:
  - Reg. Duty & H-20: #3 Deformed Bar (Gr.40) ASTM A-615, or equal
  - H-20: #4 Deformed Bar (Gr.60) ASTM A-615, or equal
- \* Effective Leaching Area: 9.2 sf/lf
- \* Approximate Capacity without stone: 720 gals
- \* Approximate Weight: 4,020 lbs.

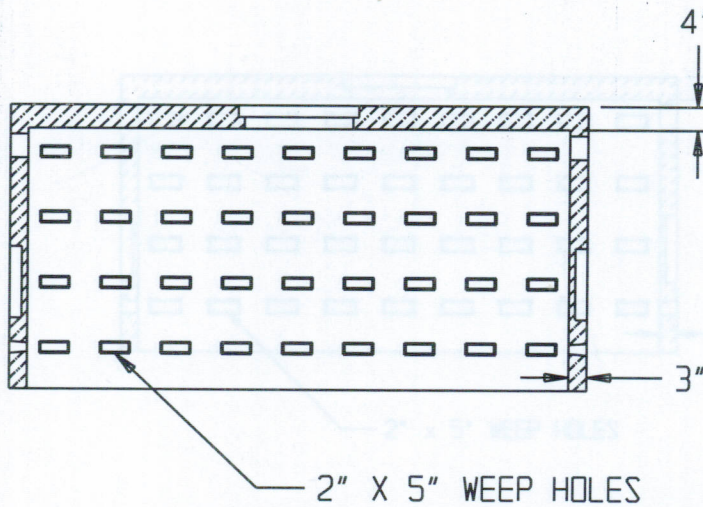
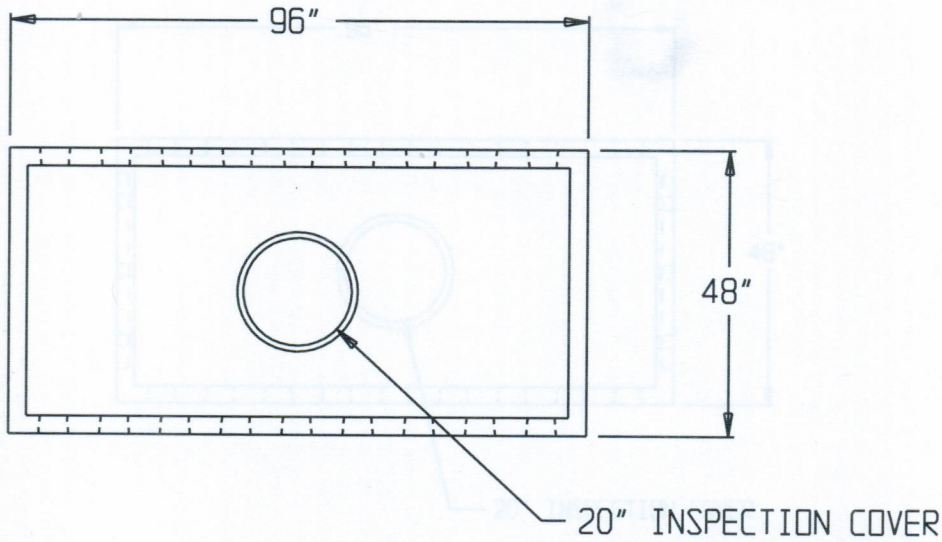

2 COMMERCE DRIVE PO BOX 5133, BROOKFIELD, CT 06804  
 PHONE: 203 775-0230 FAX: 203 740-2059 WWW.EASTERNPRECAST.COM

PROJECT			
TITLE			
DRAWN BY Brett B.		DATE 09-21-05	
SCALE 1:1	DWG. NO. LG448	SHEET 1 OF 1	REV. C